



Installation / Operation Instructions

***EZ610***  
***Low Light Inline IP66 Bullet Camera***



***EZ630***  
***Low Light IR Inline IP66 Bullet Camera***



EVERFOCUS ELECTRONICS CORPORATION

**P/N: 4605XZ0610004AR**

# Operation Instruction

---

© 2010 EverFocus Electronics Corp

Please read this manual first for correct installation and operation. This manual should be retained for future reference. The information in this manual was current when published. The manufacturer reserves the right to revise and improve its products. All specifications are therefore subject to change without notice.

All rights reserved. No part of the contents of this manual may be reproduced or transmitted in any form or by any means without written permission of the EverFocus Electronics Corporation.

## Precautions

1. Do not install the camera near electric or magnetic fields.

Install the camera away from TV/radio transmitters, magnets, electric motors, transformers and audio speakers since the electromagnetic fields generated from these devices may distort the video image.

2. Never disassemble the camera beyond the recommendations in this manual nor introduce materials other than those recommended herein.

Improper disassembly or introduction of corrosive materials may result in equipment failure or other damage.

3. Try and avoid facing the camera toward the sun.

In some circumstances, direct sunlight may cause permanent damage to the sensor and/or internal circuits.

4. Keep the power cord away from water and other liquids and never touch the power cord with wet hands.

Touching a wet power cord with hands or touching the power cord with wet hands may result in electric shock.

5. Never install the camera in areas exposed to oil, gas or solvents.

Oil, gas or solvents may result in equipment failure, electric shock or, in extreme cases, fire.

6. Cleaning

Do not touch the surface of the sensor directly with the hands. Use a damp soft cloth to remove any dirt from the camera body. Use lens tissue or a cotton tipped applicator and ethanol to clean the sensor and the camera lens. Please do not use complex solvents, corrosive or abrasive agents for cleaning.

7. Do not operate the camera beyond the specified temperature, humidity or power source ratings.

Use the camera at temperatures within  $-40^{\circ}\text{C} \sim 50^{\circ}\text{C}$  ( $-40^{\circ}\text{F} \sim 122^{\circ}\text{F}$ ) and in an IP66 complaint environment; this device is not rated as submersible. The input power source is 12VDC/24VAC.

### Federal Communication Commission Interference Statement

This equipment has been tested and found to comply with the limits for a Class A digital device, pursuant to Part 15 of the FCC Rules. These limits are designed to provide reasonable protection against harmful interference in a residential installation. This equipment generates, uses and can radiate radio frequency energy and, if not installed and used in accordance with the instructions, may cause harmful interference to radio communications. However, there is no guarantee that interference will not occur in a particular installation. If this equipment does cause harmful interference to radio or television reception, which can be determined by turning the equipment off and on, the user is encouraged to try to correct the interference by one of the following measures:

- Reorient or relocate the receiving antenna.
- Increase the separation between the equipment and receiver.
- Connect the equipment into an outlet on a circuit different from that to which the receiver is connected.
- Consult the dealer or an experienced radio/TV technician for help.

**FCC Caution:** Any changes or modifications not expressly approved by the party responsible for compliance could void the user's authority to operate this equipment.

This device complies with Part 15 of the FCC Rules. Operation is subject to the following two conditions: (1) This device may not cause harmful interference, and (2) this device must accept any interference received, including interference that may cause undesired operation.



**ATTENTION!** This is a class A product which may cause radio interference in a domestic environment; in this case, the user may be urged to take adequate measures.



This Product is RoHS compliant.

**WEE**



Your EverFocus product is designed and manufactured with high quality materials and components which can be recycled and reused.

This symbol means that electrical and electronic equipment, at their end-of-life, should be disposed of separately from your household waste.

Please, dispose of this equipment at your local community waste collection/recycling centre.

In the European Union there are separate collection systems for used electrical and electronic product.

The information in this manual was current upon publication. The manufacturer reserves the right to revise and improve his products. Therefore, all specifications are subject to change without prior notice. Misprints reserved. Please read this manual carefully before installing and using this unit. Be sure to keep it handy for later reference.

# Table of Contents

<b>1</b>	<b>Product Overview.....</b>	<b>7</b>
1.1	Features .....	7
1.2	Accessory Parts List.....	8
1.3	Specifications .....	9
1.4	Dimensions.....	10
1.5	Camera Component Description .....	11
1.6	Related Products .....	12
<b>2</b>	<b>Installation .....</b>	<b>13</b>
2.1	Wiring and Mounting.....	13
2.2	Adjust Camera Position .....	15
<b>3</b>	<b>OSD Menu Setup .....</b>	<b>18</b>
3.1	Control Key General Operation Guide.....	18
3.2	RS485 ID & Baud Rate Setting .....	19
3.3	OSD Menu Setup .....	20
3.3.1	OSD Menu Tree .....	20
3.3.2	LENS .....	21
3.3.3	EXPOSURE.....	22
3.3.3.1	SHUTTER .....	22
3.3.3.2	AGC (Auto Gain Control – basic low light signal amplification) .....	22
3.3.3.3	SENS-UP .....	22
3.3.3.4	BLC-Backlight Compensation .....	23
3.3.3.5	D-WDR .....	24
3.3.4	WHITE BALANCE CONTROL.....	24
3.3.5	DAY NIGHT .....	25
3.3.6	3DNR.....	26
3.3.7	SPECIAL .....	26
3.3.7.1	CAM TITLE .....	26
3.3.7.2	D-EFFECT .....	27
3.3.7.3	FREEZE.....	27
3.3.7.4	MIRROR .....	27
3.3.7.5	D-ZOOM .....	27
3.3.7.6	GAMMA .....	28
3.3.7.7	NEG. IMAGE .....	28
3.3.7.8	RETURN .....	28
3.3.7.9	MOTION .....	28
3.3.7.10	PRIVACY .....	28
3.3.7.11	SYNC.....	29
3.3.7.12	LANGUAGE.....	29
3.3.7.13	RETURN .....	29
3.3.8	ADJUST.....	29
3.3.8.1	SHARPNESS .....	29
3.3.8.2	BLUE .....	29
3.3.8.3	RED.....	30
3.3.9	RESET.....	30
3.3.9.1	FACTORY RESET .....	30
3.3.9.2	EXIT .....	30

<b>4</b>	<b>RS-485 Remote Control .....</b>	<b>31</b>
4.1	<i>Remote control with EKB-500 keyboard.....</i>	<i>31</i>
4.1.1	RS - 485 Wiring .....	31
4.1.2	OSD Menu Setting by Keyboard .....	31
4.1.3	Lens Adjustment by Keyboard.....	32
4.2	<i>Remote Control with EverFocus DVR.....</i>	<i>32</i>
4.2.1	RS-485 Wiring .....	32
4.2.2	Camera Operation and Setup by DVR .....	32

# 1 PRODUCT OVERVIEW

Amazing color low light sensitivity of 0.05 lux before the added benefits of advanced DSP technology, delivered by a 1/3" Sony Super HAD II sensor, is just the beginning with the new EverFocus EZ610/630. Get color without compromise: 560TVL resolution, your choice of full motion color or true day/night images in low light without ghosting, plus Digital Wide Dynamic Range to handle the most challenging of bright or unbalanced scene lighting conditions. Where ambient light levels are too low, select the EZ630 for extended IR range, variable output IR control to manage illumination and conserve energy, split glass to prevent internal IR reflections. Easy to mount and install, the camera includes a speedy-mount ring, designed to fit a standard 4" electrical box, for convenient and reliable wall or ceiling mounting; just attach the speedy-mount ring to the mounting surface and the camera base plate quickly attaches to the ring. A removeable insert in the ring provides for an on-demand slot for surface wire access. Spin off the base plate, and the EZ610/630 mates with any standard 1" conduit thread. The E-Z Lock ring at the base is designed with sure-grip tabs to firmly clamp the camera to the base plate, plus a set screw in the base provides added security. Vandal resistant, IP66, with motorized varifocal auto iris lens, dual voltage operation and a full suite of OSD Menu and DSP functions controllable at the camera or remotely via RS-485 (3D-DNR to save DVR HDD space, privacy masking, 32X digital zoom, mirroring and rotation, 256X sens-up to a max of .0002 lux, and much more) these are the cameras you have been waiting for, and might be the only cameras you'll ever need.

## 1.1 Features

- Super HAD II sensor at 0.05 lux has 5X better native light sensitivity before DSP low light boost
- Color without compromise: your choice of full motion color or true day/night images in low light without ghosting
- True Day/Night with ICR module (field selectable, if desired)
- Starlight super high sensitivity of 0.0002 Lux/F=1.2 is achieved through a sensitivity increase setting of up to 256x
- Extended IR range of up to 60M (196 feet) with 36 LEDs and variable output IR control to manage illumination and conserve energy (EZ630 model only)
- Motorized varifocal auto iris lens – choose 2.8-10mm or 9-22mm focal range
- Digital Wide Dynamic Range expansion to deliver properly exposed images despite bright light sources, deep shadows and/or unbalanced lighting in the same scene
- Provides 3D-Noise Reduction to improve picture clarity while enabling DVRs to improve disk storage utilization
- Flexible mounting and positioning – speedy-mount ring also fits a 4" round electrical box; or remove base to mate with 1" conduit
- E-Z Lock ring at the base is designed with easy to grip tabs to firmly clamp the camera in place, plus a set screw in the base for added security.
- Easy to use OSD setup menu with local or RS-485 remote control
- Motion detection for 4 configurable zones
- Privacy mask function for 8 configurable zones
- Provides digital zoom up to 32x
- Easy bottom access to video test point and lens/OSD menu controls inside a weatherproof cover

- IP66 weather resistant
- Dual voltage (12VDC/24VAC) with line lock to AC supply

## 1.2 Accessory Parts List



Please be careful when you unpack the box and the electronic device inside. Check and make sure that you have all the items listed below inside the original box:

- Camera Unit x 1
- Speedy Mount Ring x 1
- Surface Wire Slot Filler x 1 (optional, may vary in different countries)
- Operation Manual x 1
- Video Test Cable x 1
- Power Supply Pigtail x 1
- Mounting Kit x 1

Mounting kit includes:

- Long Screws x 4 (for attaching EZ Mount Ring to mounting surface)
- Short Screws x 4 (for connecting camera base to EZ Mount Ring)
- Expanding Anchors x 4
- Hex key x 1 (for adjusting camera)
- Hexagon wrench x 1 (for adjusting sunshield and set screw in base)
- Mounting Template x 1

**Note:** If an item appears to have been damaged in shipment, replace it properly in its carton and notify the shipper. If any items are missing, notify your EverFocus Electronics Corp. Sales Representative or Customer Service. The shipping carton is the safest container in which the unit may be transported. Save it for possible future use.



## 1.3 Specifications

Model	EZ610	EZ630
Pickup Device	1/3" SONY Super HAD II CCD	
Video Format	NTSC, PAL (by model)	
Picture Elements	768 x 494(NTSC)/ 752 x 582 (PAL)	
Horizontal Resolution	560 TVL	
Sensitivity	0.05Lux/F=1.2 (AGC ON); 0.0002Lux/F=1.2 (Sens-up 256x)	0.05Lux/F=1.2 (AGC ON); 0.0002Lux/F=1.2 (Sens-up 256x) ; 0 Lux IR ON
S/N Ratio	Over 52dB (AGC off)	
Electronic Shutter	1/60(1/50) ~1/100,000	
Video Output	Main Output BNC 1.0V p-p 75Ω, Local test output, cable provided.	
Gamma Correction	0.45	
Lens Type	DC Iris Varifocal: focal length 2.8-10mm (MVB) or 9-22mm (MV2) focal length	
Back Light Compensation	OFF/BLC/HS BLC Selectable	
Auto Gain Control	Low/Middle/High Selectable	
White Balance	ATW/AWB/AWC/Manual/Indoor/Outdoor Selectable	
Sync. Mode	Internal / Line lock	
Day & Night	Auto/Color/BW/EXT (True Day/Night with ICR control module)	
OSD menu	Multiple functions	
IR Emitters	N/A	36 long life LEDs
IR Configuration	N/A	Split glass isolation prevents internal reflections
IR Wavelength	N/A	850nm
IR LED Minimum Lifespan	N/A	20,000 hours of operation
IR Range	N/A	Up to 60M (196ft) <AGC ON>
IR Output	N/A	Intelligent Variable Intensity Illumination/Energy Management
3D-DNR	Off/On switchable	
Digital WDR	Outdoor / Indoor	
Digital Slow Shutter	Sens-Up 256X	
Mirror	Off/Mirror/V-Flip/Rotate Selectable	
Digital Zoom	Off/On selectable up to 32X	
Motion Detection	Off/On for 4 selectable zones	
Privacy Mask	Off/On for 8 selectable zones	
RS-485	Control input for menu/configuration	
Power Source	12VDC/24VAC	
Power Consumption	12VDC: 8W max. 24VAC: 9W max.	
Operating Temperature	-40°C~50°C ; -40°F~122°F (built-in heater)	
Weatherproof	IP66 rated	
Vandal Resistant	Yes	
Dimensions	316.2mm (L) x 82.5mm (H) x 105.5mm Diameter (W) ; 12.49 in. (L) x 3.24 in. (H) x 4.15 in. Diameter (W)	

Weight	1250 g / 2.275 lbs.
Mounting Pattern	Speedy-Mount Ring mates with 4" round electrical box; base swivel is 1" NPT – remove base plate for coupling to standard conduit fittings.
Certifications	CE / FCC

## 1.4 Dimensions

Front view

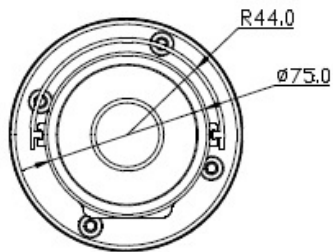

Camera Body

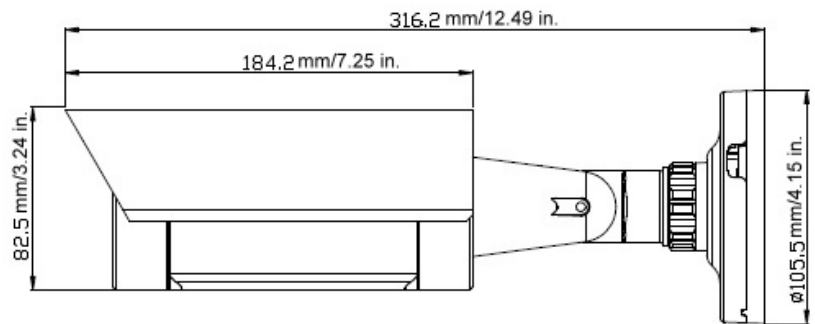

## 1.5 Camera Component Description

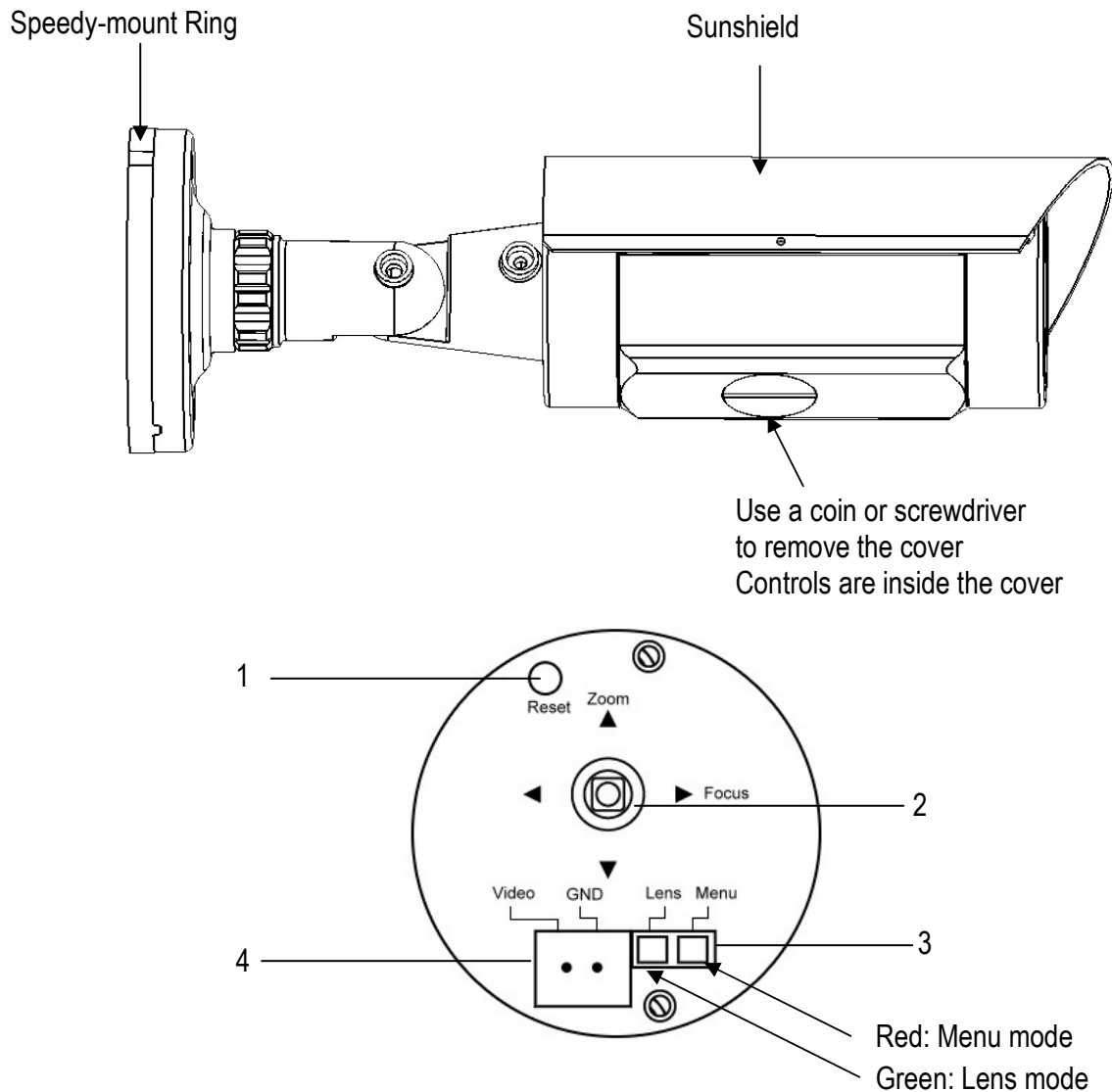

- 1) Reset:** To load the factory default configuration press the button, which is inside this hole, for 3 seconds. Please gently insert a thin, non-metallic device into the hole to operate the reset button.
- 2) Control Key:** For setting Lens & OSD menu. Press the mini-joystick and hold for 5 seconds to switch between Lens & Menu setting. When the camera is in Lens mode, turn the mini-joystick up (▲) or down (▼) to zoom in/ zoom out. Turn the mini-joystick left (◀) or right (▶) to adjust focus.
- 3) Lens/Menu:** Lens LED will turn green when you select the Lens adjustment mode. Menu LED will turn red when you select the Menu setting mode.
- 4) Video/GND:** for aim and focus access to video at the camera, use the Video Test Cable supplied to connect to a hand held test monitor (EN220 or similar).

## 1.6 Related Products

In addition, you may order the following EverFocus products which are recommended for use with the camera to achieve the best performance:

- EverFocus control keyboard (EKB500)
- Any EverFocus DVR with RS-485 interface for PTZ control

## 2 INSTALLATION

This chapter will describe, in general terms, how to install the EZ610/630 camera.

### STEPS:

1. Wire and mount the camera. See 2.1
2. Adjust the camera position. See 2.2

### Warning

To prevent electrical shock, turn off the electrical power before making electrical connections.

### 2.1 Wiring and Mounting

Use the template and an appropriate tool to drill 4 holes to attach the speedy-mount ring. If no surface wire will be used, please insert the provided plug into the ring from the underside; the plug will be held securely in place by the ring. If surface wire access is required, simply omit the plug to leave the surface wire channel clear.

Push the plastic anchors into the 4 holes.



3. Take a long Phillips pan head screw and tighten it through the EZ Mount Ring counter-bored hole into a plastic anchor. Repeat this step until all 4 screws are secured to the wall/ceiling.

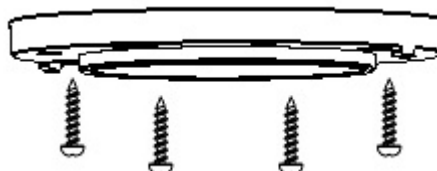

4. Drill a 1" diameter hole within the interior of the EZ Mount Ring.
5. Pull the cables to be connected to power & video cables from the ceiling or wall.

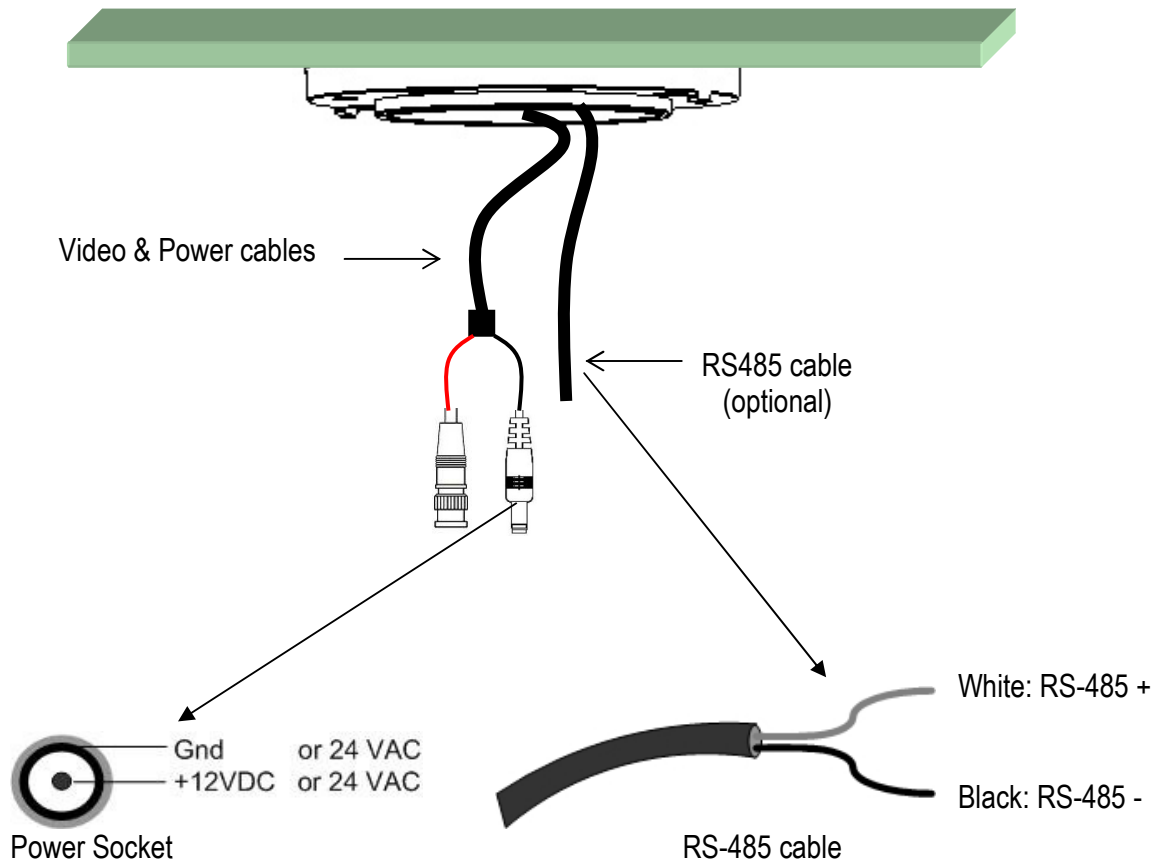

Connect the power and video cables. Attach the camera to the speedy-mount ring, securing it with the 4 socket head cap screws provided.

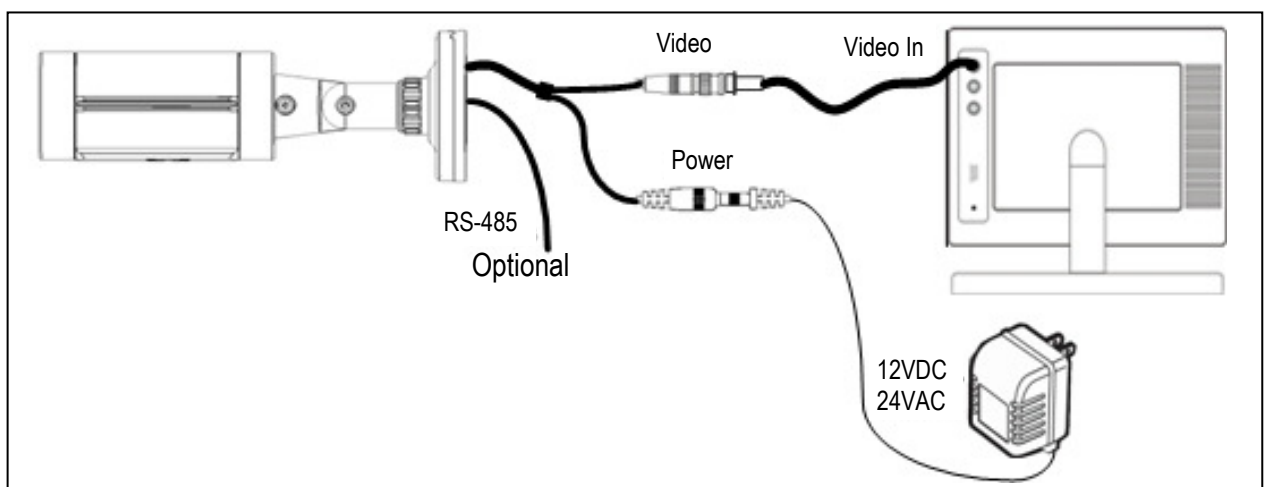
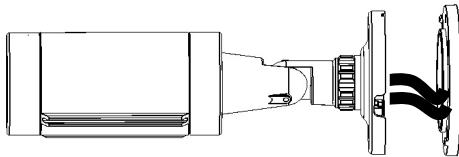

Power and Video connection:

**Note:** For details of RS-485 connection please consult chapter 4, for RS-485 setup chapter 3.2!

## 2.2 Adjust Camera Position

Adjust the viewing angle to the desired direction. With this unique 3-axis positioning system, installers can capture images from virtually any angle, without compromising. The camera can be adjusted in 3 ways.

### 1st axis

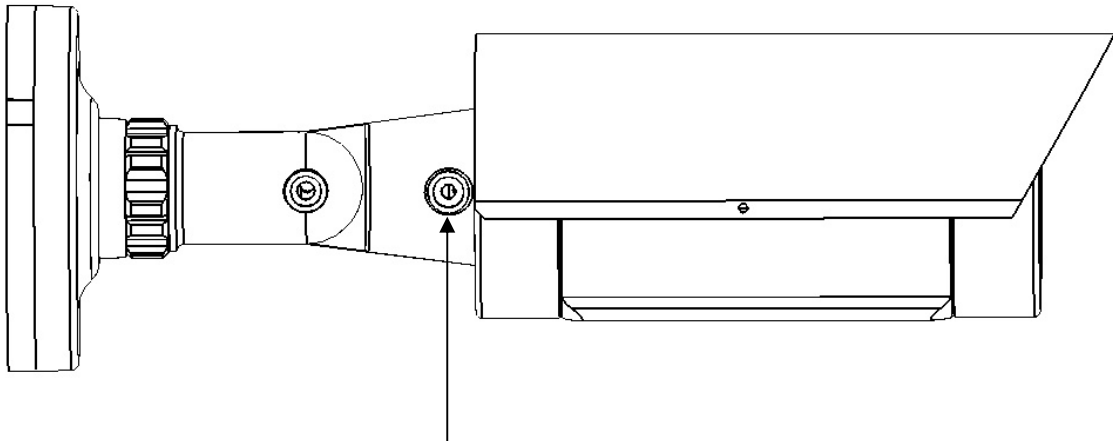

Use a hexagon key to loosen this screw to rotate the camera 360°

### 2nd axis

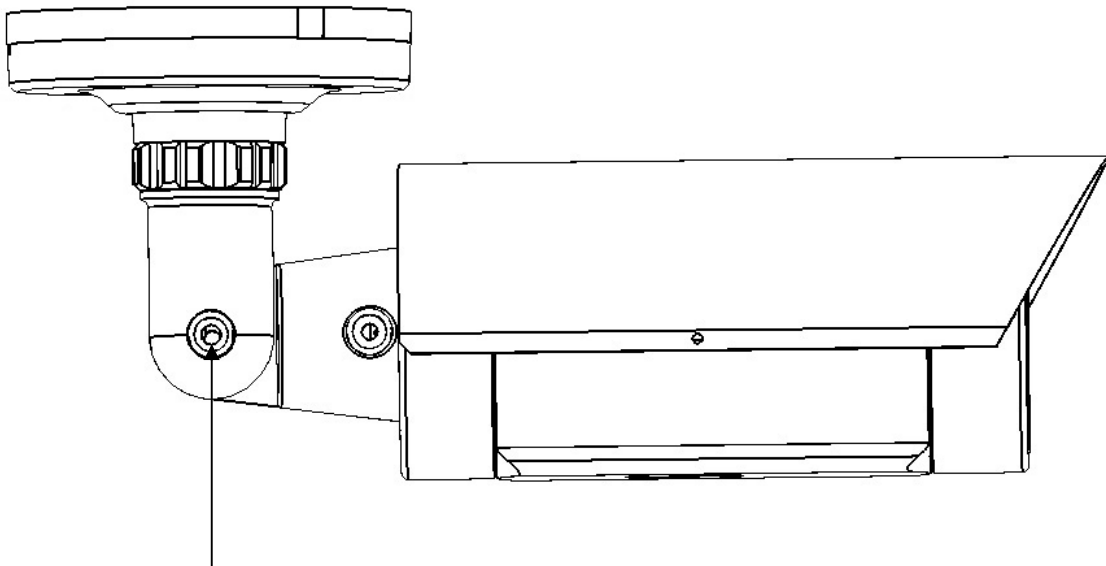

Use a hexagon key to loosen this screw to rotate the camera 180°

### 3rd axis

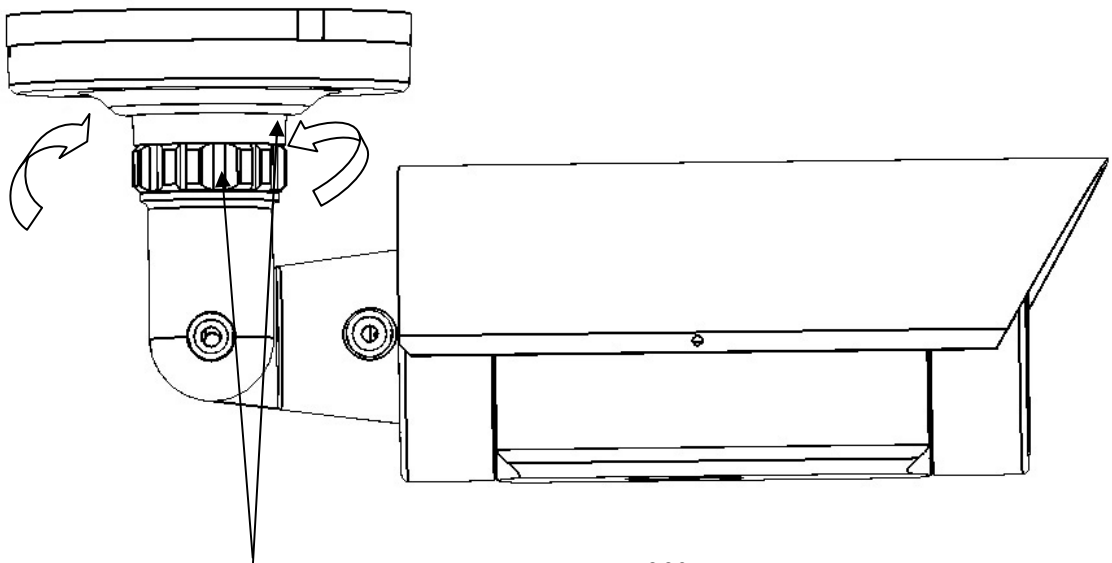

Loosen lock ring and set screw to rotate camera 360°

### Sunshield

To remove or install the sunshield, use the hexagon wrench provided to loosen the screw at sunshield.

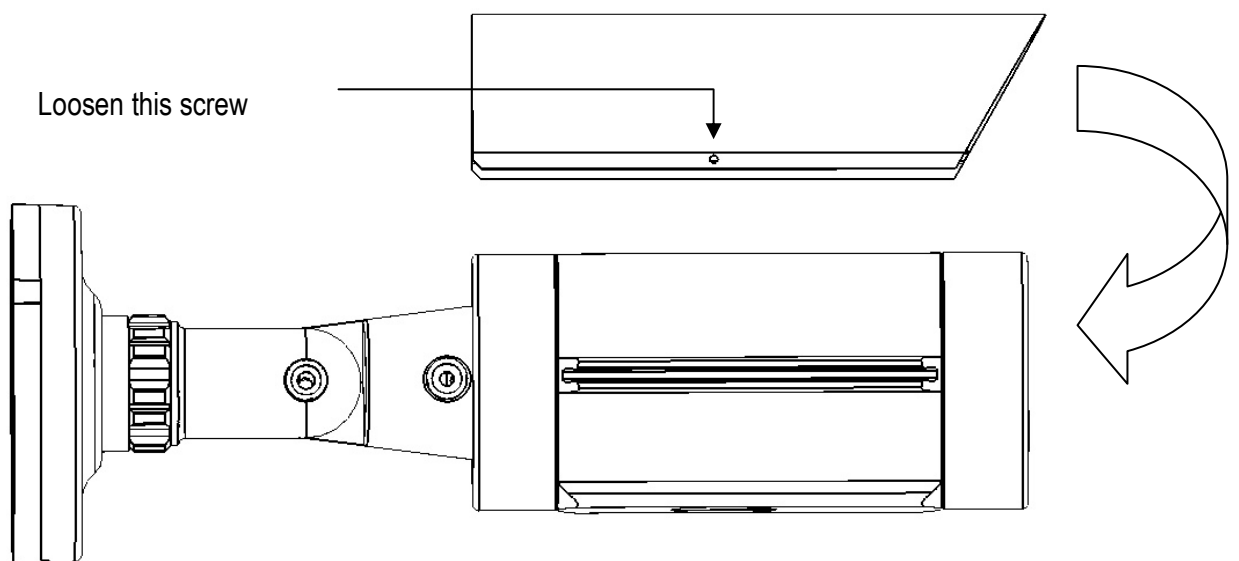

Loosen this screw

Slide rib on interior of sunshield into track on outside of camera body from front to back.



**Note:** When properly installed, the rear of the sunshield is even with the rear of the camera body; improperly extending the sunshield to 'shade' the lens can compromise image quality, particularly on the EZ630 IR model.

## 3 OSD MENU SETUP

This chapter introduces how to change RS485 ID and Baud Rate and to configure the camera OSD menu.

### STEPS

If you want to connect to the camera with a keyboard or other RS-485 - controller, please refer to Section 3.2 RS485 ID & Baud Rate setting. Otherwise, please go to STEP 2.

Configure the camera, as described below:

### 3.1 Control Key General Operation Guide

#### Switch between Lens and Menu operation

Press and hold (~ 5 s) the joystick button for changing the operation mode of the joystick. Red LED: Menu mode, Green LED lens control mode.

#### Bring Up the General OSD Menu

Simply press the mini-joystick to bring up the general OSD menu.

**Note:** Make sure, that the joystick is in "MENU" mode (red LED under Joystick).

#### Navigate among the OSD Menu Items

Angle the mini-joystick up (▲) or down (▼) to move the cursor up or down.

#### Change Modes or Setting Parameters

Angle the mini-joystick left (◀) or right (▶) to adjust the mode or value of settings.

#### Switch to Sub-menu Screens

When an item with a sub-menu is selected, press in on the mini-joystick to switch to the sub-menu for further settings. This may also be referred to in the instructions below as "pressing the setup button". Please refer to the diagram below.

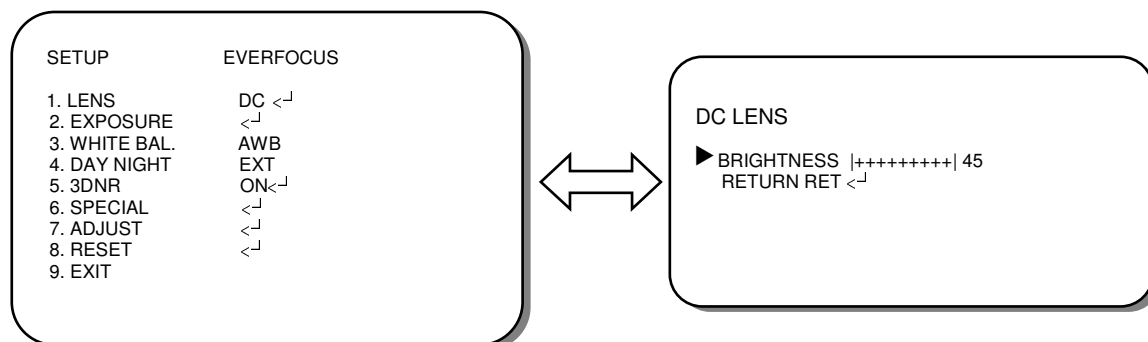

**NOTE:** For those selected items with “ ◀ ” sign in the end, there is a sub-menu for further settings.

### Return to Previous Page

Go to “Return” by turning the mini-joystick and press the mini-joystick to return to previous page.

### Close the Host Menu Screen

To close the menu screen, navigate to the “EXIT” item and press the mini-joystick.

## 3.2 RS485 ID & Baud Rate Setting

Default setting for RS-485 is:

**Protocol:** EverFocus or Pelco-D, self detecting (no setup required)  
**Baud rate:** 9600  
**RS-485 ID:** 1

The setup of RS-485 parameters should be done as **first** step of camera OSD setup, because a camera reset is required for this.

Press the RESET key with a thin tool and hold for ~3 seconds.

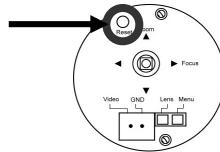

The camera will perform a factory reset, after this the current RS-485 address is shown on the top of the screen:

Example: **ID 01**

RS485 ID is adjustable in the range 001~128. Default value is 01. Move joystick UP and Down to adjust it. Press “Set” key to confirm the setting.

Now the current Baud Rate appears on the top of the screen:

Example: **9600**

The Baud Rate is adjustable for the values 9600, 4800, 2400 and 1200. Default value is 9600. Move joystick UP and Down to adjust it. Press “Set” key to confirm and finalize the setting.

**Note:** 1. For camera protocol, EZ610/630 recognizes Everfocus or Pelco-D protocols automatically (No setting is required).

2. Camera ID and baud rate setting can only be performed locally, not from Keyboard.

3. RS-485 ID and Baud rate have to match the controller settings for this camera and the connected RS-485 port.

### 3.3 OSD Menu Setup

#### 3.3.1 OSD Menu Tree

Default settings are shown bold or in brackets.

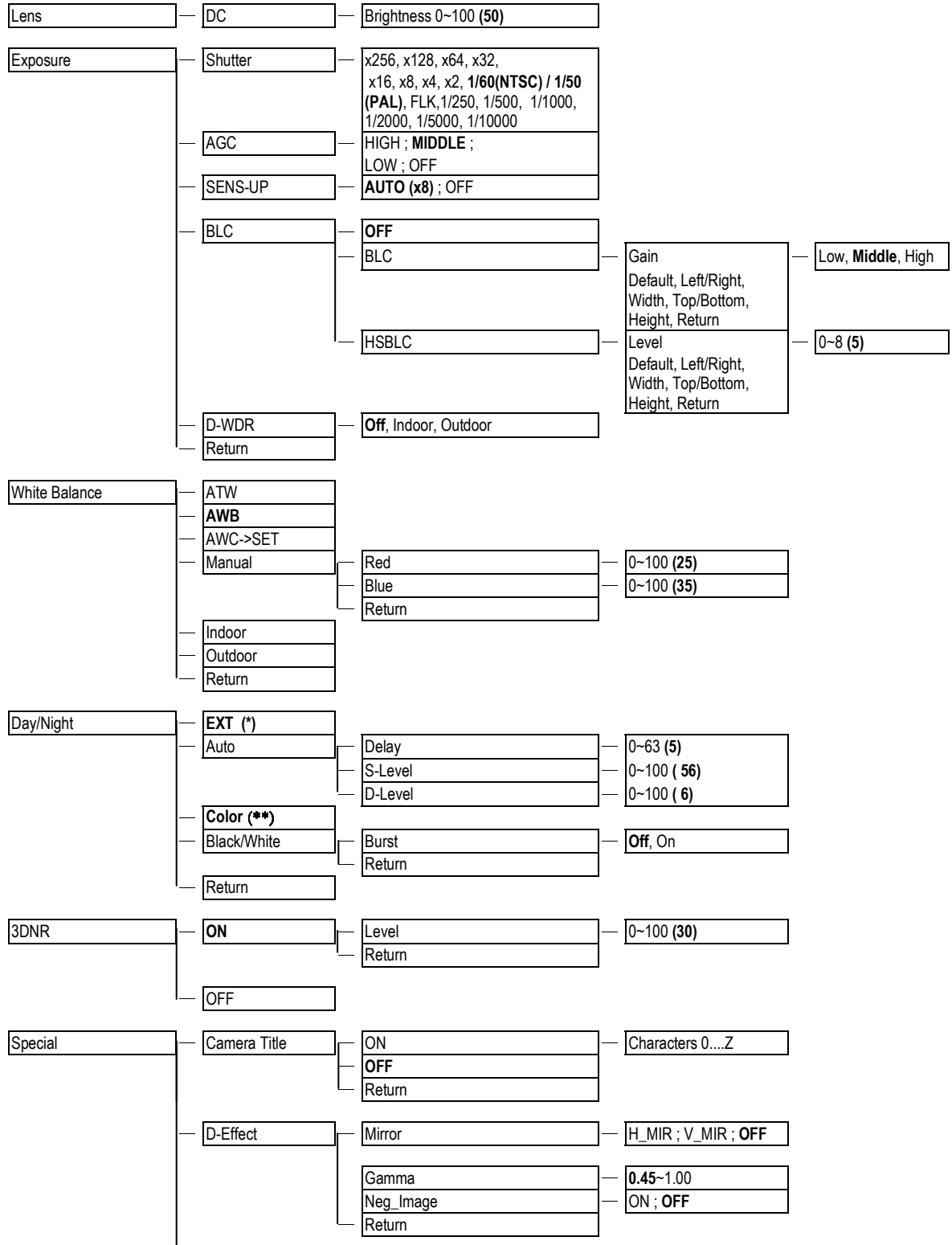

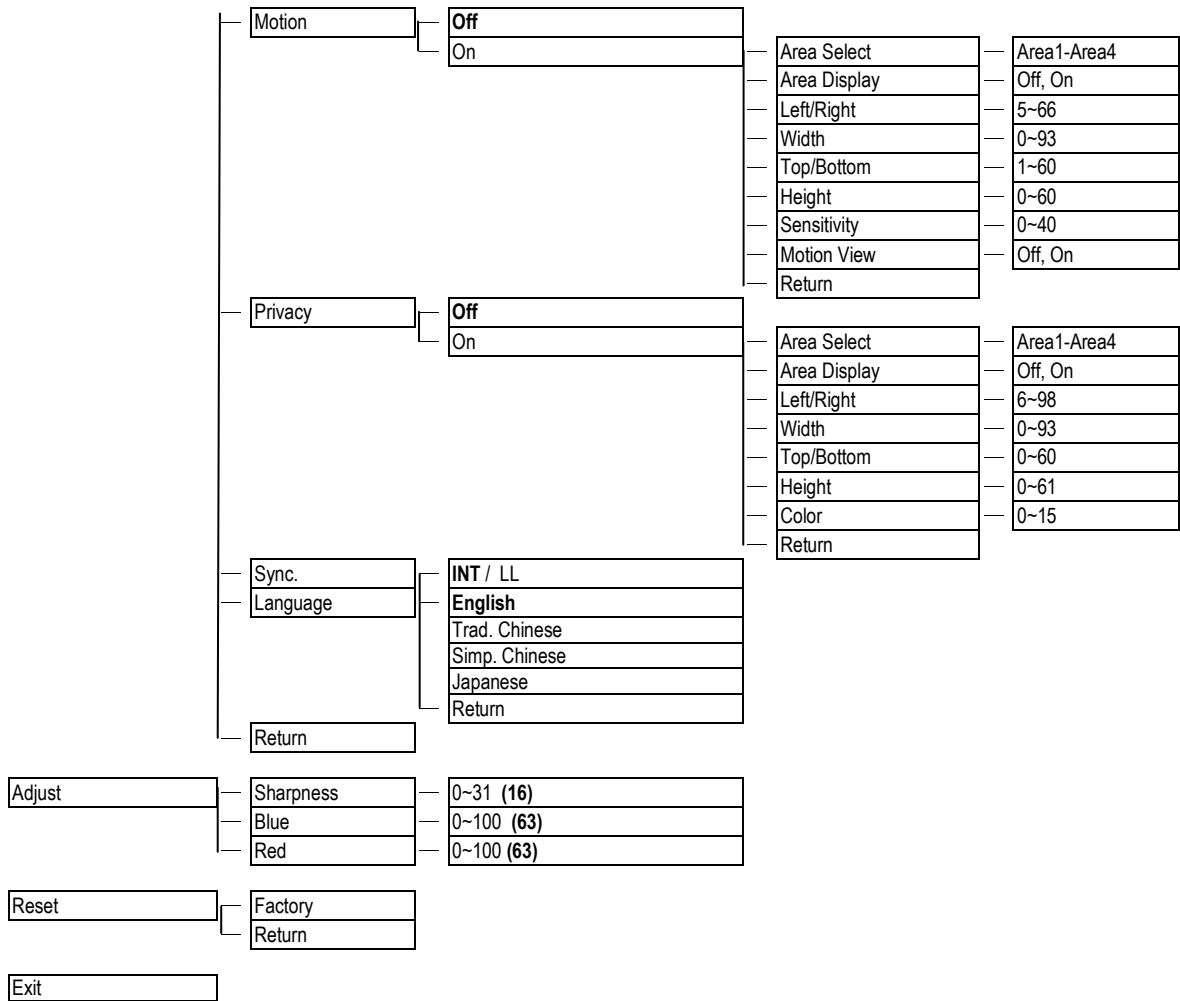

\* EXT: Default value for EZ630  
 \*\* Color: Default value for EZ610

### 3.3.2 LENS

When the SETUP menu is displayed on the screen, please direct the arrow to point to "LENS" by using the UP and DOWN buttons.

The iris opening can be adjusted in DC mode in LENS LEVEL. The level can be adjusted from 0 to 50.

Please select RETURN and press the SETUP button if you would like to return to the previous menu.

### 3.3.3 EXPOSURE

#### 3.3.3.1 SHUTTER

1. When the SETUP menu is displayed on the screen, please direct the arrow to point to “EXPOSURE” -> “SHUTTER” by using the UP and DOWN buttons.
2. Select the shutter mode by pressing the LEFT or RIGHT button.  
Select from x256, x128, x64, x32, x16, x8, x4, x2, **1/60 (1/50 at PAL)**, FLK, 1/250, 1/500, 1/1000, 1/2000, 1/5000, 1/10000, 1/100000 for NTSC model or x256, x128, x64, x32, x16, x8, x4, x2, 1/50, FLK, 1/250, 1/500, 1/1000, 1/2000, 1/5000, 1/10000, 1/100,000 for PAL model.  
FLK: Please select “FLK” mode when flickering occurs on the screen, because of an irregular balance between illumination and frequency. NTSC model: 1/100, PAL model: 1/120.
3. Select RETURN and press the SETUP button when you finish all the settings.

**NOTE:** Make sure for default setting 1/60 (NTSC) / 1/50 (PAL), if SENS-UP function is needed in the installation. All other Shutter modes will disable SENS-UP functionality.

#### 3.3.3.2 AGC (Auto Gain Control – basic low light signal amplification)

Please direct the arrow to point to “AGC” by using the UP and DOWN buttons.  
Select the level you would like to choose by pressing the LEFT or RIGHT button. The more the level of gain increases, the brighter the screen, but the level of noise increases as well. Please select from HIGH, **MIDDLE**, LOW and OFF.  
Note: AGC must be on for sense-up low light boost to function.

#### 3.3.3.3 SENS-UP

SENS-UP is used to keep a brilliant, vivid screen image under low light level conditions by automatically compensating for changes in the level of light.  
Please direct the arrow to point to “SENSE-UP” by using the UP and DOWN buttons.  
Select the mode you would like to operate by pressing the LEFT or RIGHT button.  
**AUTO:** Low light level auto mode. Press SET for adjusting the maximum number of interpolated images. (Default is Auto, 8X)  
**OFF:** The function is disabled.  
Press select RETURN and the SETUP button when you finish all the settings.

**NOTE:** 1. SENS-UP will be disabled, if AGC is OFF or the default SHUTTER value (1/50 PAL / 1/60 NTSC) was changed

2. The image becomes brighter when the setting increases; however, the after image increases as well. Due to the increased light sensitivity of the Super HAD II chip, far less DSP ‘boost’ is needed, resulting in color or B/W images in low light with minimal ghosting.

3. Please note that spots and noise may appear if light amplification increases when SENSE-UP is operating. This is a normal phenomenon, controllable with DNR.

### 3.3.3.4 BLC-Backlight Compensation

There are three choices for the type of BLC which may be employed: OFF, traditional BLC or HSBLC.

#### **BLC**

Video gain can be adjusted automatically to correct the exposure of subjects that are in front of a bright light source.

Please direct the arrow to point to "BLC" by using the UP and DOWN buttons.

Select the BLC mode by pressing the LEFT or RIGHT button. Then make adjustments as below:

<b>GAIN</b>	Select from High, Middle and Low.
<b>DEFAULT</b>	Set the factory default values for BLC.
<b>LEFT/RIGHT</b>	Set the Left/Right side of an area for the BLC to be adjusted. The value adjustable is 0~6.
<b>WIDTH</b>	Set the width of an area for the BLC to be adjusted. The value adjustable is 0~6.
<b>TOP/BOTTOM</b>	Set the Top/Bottom side of an area for the BLC to be adjusted. The value adjustable is 0~6.
<b>HEIGHT</b>	Set the height of an area for the BLC to be adjusted. The value adjustable is 0~6.
<b>RETURN</b>	Press "RET" to save all settings in the BLC menu and return to the previous menu. Press "END" to save all the menu settings and exit.

#### **HSBLC**

HSBLC (Highlight Suppression BLC) is used to reduce the brightness of light sources in a specific area. It is activated only in a low illumination environment to minimize the effects of glare from bright lights such as spotlights, street lights or headlights in the field of view. Where 'traditional' BLC can increase the exposure of a dark area surrounded by a brighter area, HSBLC can decrease the exposure of bright areas surrounded by darker areas.

1. Please direct the arrow to point to "BLC" by using the UP and DOWN buttons.

2. Select the HSBLC mode by pressing the LEFT or RIGHT button. Then make adjustments as below:

<b>LEVEL</b>	Adjust the sensitivity level for HSBLC from 0 to 8.
<b>DEFAULT</b>	Set the factory default values for HSBLC.
<b>LEFT/RIGHT</b>	Set the Left/Right side of an area for the HSBLC to be adjusted. The value adjustable is 0~6.
<b>WIDTH</b>	Set the width of an area for the HSBLC to be adjusted. The value adjustable is 0~6.

- TOP/BOTTOM** Set the Top/Bottom side of an area for the HSBLC to be adjusted. The value adjustable is 0~6.
- HEIGHT** Set the height of an area for the HSBLC to be adjusted. The value adjustable is 0~6.
- RETURN** Press “RET” to save all settings in the HSBLC menu and return to the previous menu.  
Press “END” to save all the menu settings and exit.

### 3.3.3.5 D-WDR

When there are both bright and dark areas in the field of view at same time, this function can help to even the exposure between these areas.

1. Please direct the arrow to point to “D-WDR” by using the UP and DOWN buttons.
2. Select the mode you would like to operate by moving the joystick LEFT or RIGHT.

- OFF** Disables D-WDR function (default)
- INDOOR** Select this option if you are in an indoor environment.
- OUTDOOR** Select this option if you are in an outdoor environment.
- Return Press “RET” to save all settings in the Exposure menu and return to the previous menu.  
Press “END” to save all the menu settings and exit.

### 3.3.4 WHITE BALANCE CONTROL

The screen color can be adjusted by using the WHITE BALANCE function.  
Please direct the arrow to point to “WHITE BAL” by using the UP and DOWN buttons.  
Please select the mode you would like to operate by pressing the LEFT or RIGHT button.

Please select one of the 6 modes below:

- ATW** Auto Tracking White Balance: This mode can be used within the color temperature range from 5,500°K to 6,000°K (eg, fluorescent light, outdoor, sodium vapor lamp or inside tunnels).
- AWB** Auto White Balance: This mode can be used within the color temperature range from 2,500°K to 10,000°K. (default)
- AWC ->SET** To find the optimal setting for the current luminance environment in this mode, point the camera toward a sheet of white paper, and press “SET”. If the environment changes, you will have to readjust it.



**MANUAL** The manual adjustment mode enables a more precise adjustment. Please select ATW or AWC first. Then change to manual adjustment mode and press the SETUP button. Set the suitable color temperature, and increase or decrease the red and blue color values at the same time while checking the color changes of the objects in view.  
Press "RET" to save all settings in this menu and return to the previous menu.  
Press "END" to save all the menu settings and exit.

**INDOOR** Select this option when the color temperature is 5,600°K.

**OUTDOOR** Select this option when the color temperature is 3,300°K

Press "RET" to saves all settings in this menu and returns to the previous menu.  
Press "END" to save all the menu settings and exit.

### 3.3.5 DAY NIGHT

These settings control the operation of the camera when the illumination level changes. Choices are Color at all times; B/W at all times; or color when illumination is bright, switching to B/W in low light. PLEASE NOTE: In "color" operation, there is an IR "cut" (blocking) filter between the lens and the sensor; the EZ630 has **very little IR sensitivity when the image is displayed in color**. The EZ630 camera will have excellent IR sensitivity when displaying a low light B/W picture. **To properly utilize the IR illuminators on the EZ630 in low light situations, it is essential to select either the AUTO or the B/W operating mode in this menu.**

**B/W** The picture is always displayed in B/W.  
**BURST** OFF/ON:  
**ON:** Retains the color burst information; minor color noise may appear when ambient illumination is low.  
**OFF:** With color burst signal off, picture will be pure B/W.  
Press "RET" to save all settings in the DAY/NIGHT menu and returns to the previous menu.  
Press "END" to save all the setting menus and exit.

**COLOR** The picture is always displayed in color, even at low light levels.  
NOTE: In "color" operation, there is an IR "cut" (blocking) filter between the lens and the sensor; thus EZ610/630 camera has very little IR sensitivity when the image is displayed in color. (default for EZ610)

**AUTO** The picture switches to color in a normal (bright) environment and switches to B/W when the ambient illumination is low. The switching point is controlled by the video signal level.  
**Note:** AGC selection must be set as middle or high in order to employ the auto switching function.

**Delay** Delay time for switch reaction on light changes, range 0~63 seconds.

**S-Level** Trigger level for switching to day mode in range 0~100.

**E-Level** Trigger level for switching to night mode in range 0~100.

**NOTE:** The AUTO mode is not recommended for applications with high-power IR illumination. The camera may switch continuously between Day and Night mode.

**EXT** The picture will switch automatically to color in a normal environment and to B/W when the ambient illumination is low based on the illumination reaching the light sensor at the front of the camera body. (default for EZ630)

### 3.3.6 3DNR

3DNR reduces the background noise in a low luminance environment.

**OFF** Disables 3DNR to keep the same amount of noise.  
**ON** Enables 3DNR to reduce the noise. (default)  
**Level** Noise reduction level from 0~100 while observing a low light image until the desired image is achieved. (default=30)

Press "RET" to save all settings in DNR menu and returns to the previous menu.

Press "END" to save all the setting menus and exit.

### 3.3.7 SPECIAL

In this section, user can do special settings including camera title, digital effects, motion, privacy zones, synchronization and language.

Please direct the arrow to point to "SPECIAL" on the SETUP menu by using the UP and DOWN buttons.

Select the mode you would like to operate by pressing the LEFT or RIGHT button.

#### 3.3.7.1 CAM TITLE

Input the camera title, and it will be appeared on the monitor.

Please direct the arrow to point to "CAM TITLE" by using the UP or DOWN button.

Select "ON" by pressing the LEFT or RIGHT button.

Press SETUP button.

Maximum 15 characters can be used for the ID.

Use UP, DOWN, LEFT and RIGHT buttons to move the cursor to the letter to be chosen.

Use SETUP button to choose that letter.

Once a name has been selected, please choose the position on the screen where you would like to display the name.

Move the cursor onto "POS" and press the SETUP button.

The name will appear at the top left hand corner.

Please use the 4 directional buttons to move the position of the displayed name.

Press the SETUP button when the desired location has been reached.

If you would like to cancel the ID entered, please move the cursor to "CLR", and all the letters entered will be deleted.

Select "END" and press the SETUP button to complete ID input.

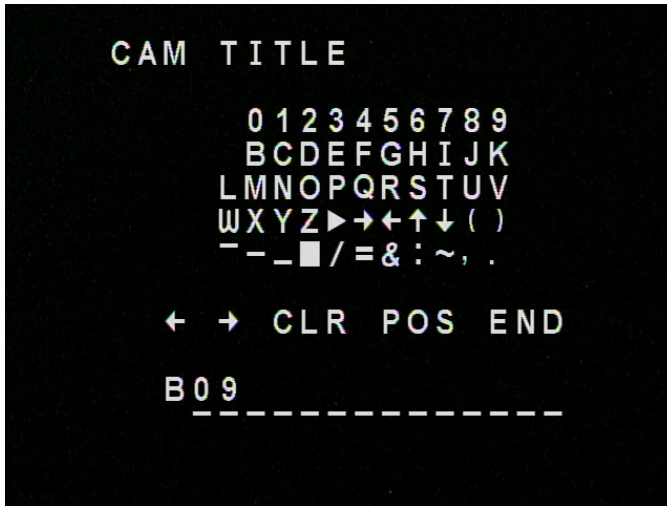

### 3.3.7.2 D-EFFECT

Offers a number of digital functions for processing the image.

### 3.3.7.3 FREEZE

- OFF**                Select "OFF" to view live image.  
**ON**                     Select "ON" to freeze and display current live image.

### 3.3.7.4 MIRROR

- OFF**                    Disable digital effects.  
**MIRROR**                The image is displayed horizontal flipped.  
**V-FLIP**                 The image is displayed vertical flipped.  
**ROTATE**                Rotate the image 180°.

### 3.3.7.5 D-ZOOM

Setup for digital zoom.

- OFF**                    Disable the D-ZOOM function  
**ON**                     **D-Zoom:** Select digital zoom from X1.0 up to X32. Note that zoom levels above X4 may lead to excessive pixellation.  
                             Setup of the position of the magnified image in view (0 is the center of the image):  
                             **Pan:** Select digital pan from -100 to 100.  
                             **Tilt:** Select digital tilt from -100 to 100.

Press "RET" to saves all settings in D-ZOOM menu and returns to the previous menu.  
 Press "END" to save all the setting menus and exit.

### 3.3.7.6 GAMMA

This menu allows adjustment of gamma correction for ideal linearity of image brightness and contrast in the range 0.05 to 1.0.

### 3.3.7.7 NEG. IMAGE

Allows user to create a negative of the original image. A negative image is a tonal inversion of a positive image, in which light areas appear dark and vice versa. A negative color image is additionally color reversed, with red areas appearing cyan, greens appearing magenta and blues appearing yellow.

### 3.3.7.8 RETURN

Return: Press "RET" to save all settings in D-EFFECT menu and return to the previous menu. Press "END" to save all the menu settings and exit.

### 3.3.7.9 MOTION

This camera enables you to observe movements of objects in 4 different areas on the screen, and the message "MOTION DETECTED" appears on the screen when movement is detected. The camera detects an object's movement by sensing changes in the pixels displayed.

<b>OFF</b>	Disables the MOTION function.
<b>ON</b>	
<b>AREA SELECT</b>	Please select the area you would like to detect from the 4 areas in AREA SELECT mode
<b>AREA DISPLAY</b>	Select "ON" to use the motion area selected in sensitivity. Select "OFF" to disable this function.
<b>LEFT/RIGHT</b>	Set the coordinate of the horizontal axis 5~66.
<b>WIDTH</b>	Set the size of horizontal area 0~93.
<b>TOP/BOTTOM</b>	Set the coordinate of the vertical axis 1~60.
<b>HEIGHT</b>	Set the size of vertical area 0~60.
<b>SENSITIVITY</b>	Set the sensitivity level for the motion trigger by selecting from 0~40. When the sensitivity value is high, motion detection sensitivity increases to sense very small movements and vice versa.
<b>MOTION VIEW</b>	Select "ON" to display motion detection pixels in the live view.
<b>RETURN</b>	Press "RET" to save all settings in MOTION menu and return to the previous menu. Press "END" to save all the menu settings and exit.

### 3.3.7.10 PRIVACY

This mode masks areas you do not want to display on the screen or record.

<b>OFF</b>	Disable the PRIVACY function.
<b>ON</b>	
<b>AREA SELECT</b>	Please select the area you would like to hide from the 8 areas in AREA

<b>AREA DISPLAY</b>	SELECT mode. Select "ON" to use the area selected in the AREA SELECT. Select "OFF" to disable this function.
<b>LEFT/RIGHT WIDTH</b>	Set the coordinate of the horizontal axis 6~98. Set the size of horizontal area 0~93.
<b>TOP/BOTTOM HEIGHT</b>	Set the coordinate of the vertical axis 0~60. Set the size of vertical area 0~61.
<b>COLOR</b>	Set area color. It is selectable from 0 to 15.
<b>RETURN</b>	Press "RET" to save all settings in PRIVACY menu and return to the previous menu. Press "END" to save all the menu settings and exit.

### 3.3.7.11 SYNC

There are two SYNCHRONIZATION modes INTERNAL and LINE-LOCK. In LINE-LOCK mode, the video signal is synchronized to the frequency of the incoming AC power. The Line-Lock synchronization can only be used when the supply power is 24VAC 60Hz (NTSC models) or 50Hz (PAL models).

<b>INT</b>	Internal synchronization
<b>L/L</b>	Line-lock synchronization (only for 24 VAC)

### 3.3.7.12 LANGUAGE

Select OSD language. EZ610/630 camera supports multiple languages including English, Japanese, Traditional Chinese and Simplified Chinese.

### 3.3.7.13 RETURN

Press "RET" to save all settings in the SPECIAL menu and return to the previous menu. Press "END" to save all the menu settings and exit.

## 3.3.8 ADJUST

Adjust sharpness, Blue and Red level in this section.

### 3.3.8.1 SHARPNESS

The contour of the video image becomes cleaner and more easily distinguished as the level of SHARPNESS increases. If the level is set too high, it may affect the video image and cause noise. The available range of level is 0~31.

### 3.3.8.2 BLUE

Adjust image's blue level. The available range of level is 0~100.

### 3.3.8.3 RED

Adjust image's red level. The available range of level is 0~100.

Press "RET" to saves all settings in the ADJUST menu and returns to the previous menu.  
Press "END" to save all the menu settings and exit.

### 3.3.9 RESET

#### 3.3.9.1 FACTORY RESET

Reset to the factory default settings.

Press "RET" to return to the previous menu.  
Press "END" to exit.

#### 3.3.9.2 EXIT

Save all the menu settings and exit.

<p><b>NOTE:</b> If you quit a Menu without pressing EXIT, all the settings you previously modified will NOT be saved.</p>
---

## 4 RS-485 REMOTE CONTROL

### 4.1 Remote control with EKB-500 keyboard

#### 4.1.1 RS - 485 Wiring

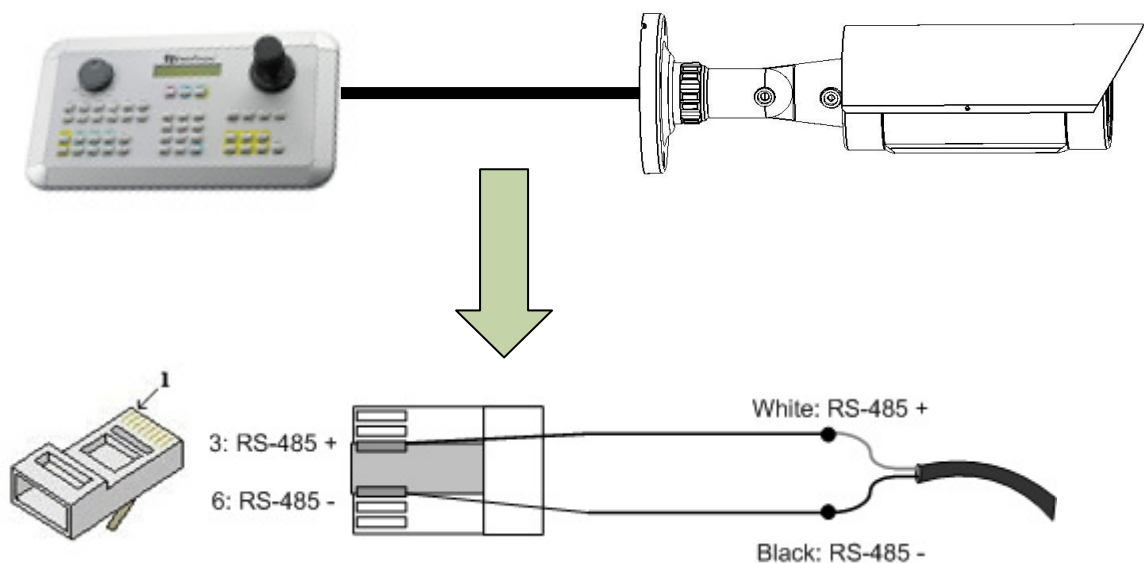

For more details about RS-485 wiring please consult related chapters in EKB-500 user manual.

#### **Note!**

Before being able to control keyboard, make sure Keyboard RS485 camera ID, Baud rate match the camera. (see COM port and CAMERA setting in EKB500 manual). EZ610/630 camera ID default is 01. Baud rate is 9600. Supported Protocols are EverFocus and Pelco-D. The camera detects the protocol of incoming commands automatically.

#### 4.1.2 OSD Menu Setting by Keyboard

- On the EKB500, choose the Camera (Camera ID) to be controlled. Then press "Menu" to enter the SETUP menu.
- Move the joystick UP (▲) and DOWN (▼). This allows you to move between selection items in the setup menu.
- If the item has sub-menu setting (sign ◀), press "Menu" again to display the sub-menu.

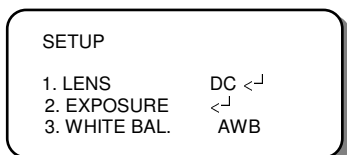

d. Move the joystick RIGHT (▶) and LEFT (◀) to adjust the mode and parameters of the selected item.

Press “Menu” to leave and goes to previous menu after setting. Move to “exit” and press “menu” button when you finish all settings.

For detail setting of each setup function, Please refer to “3.3. OSD Menu Setup”.

#### 4.1.3 Lens Adjustment by Keyboard

1. Press Zoom in or Zoom out to adjust zoom; or turn the Joystick clockwise to zoom out, and counterclockwise to zoom in.
2. Press Focus N or Focus F to adjust focus.

### 4.2 Remote Control with EverFocus DVR

#### 4.2.1 RS-485 Wiring

The connection to the DVR depends on DVR type. The EverFocus EDSR and EDR series (MPEG4) provide 2 looped RJ45 sockets with same pinout as EKB-500 keyboard (chapter 4.1.1). The DVR of Paragon and ECOR series as well as EverFocus video server have 2-pin screw terminal connectors for RS-485 interface.

#### 4.2.2 Camera Operation and Setup by DVR

The DVR have different layout and functionality for PTZ control.

If the DVR does not provide buttons for PTZ OSD menu, following alternative commands can be used for EZ610/630 OSD menu:

<b>Set Preset 95</b>	Open OSD menu
<b>Iris open (Iris +)</b>	Enter / Set
<b>Iris close (Iris -)</b>	ESC / Close OSD menu



# EverFocus Electronics Corp.

## Headquarters Office

12F, No.79 Sec.1 Shin-Tai Wu Road,  
Hsi-Chi, Taipei, Taiwan  
Tel: +886-2-26982334  
Fax: +886-2-26982380

## Beijing office

Room 609, Technology Trade Building,  
Shangdi Information Industry Base,  
Haidian District, Beijing China  
Tel: +86-10-62971096  
Fax: +86-10-62971423

## European Office

Albert-Einstein-Strasse 1,  
D-46446 Emmerich, Germany  
Tel: +49-2822-9394-0  
Fax: +49-2822-939495

## Japan Office

5F Kinshicho City Building, 2-13-4 Koto-bashi,  
Sumida-Ku, Tokyo, 130-0022, Japan  
Tel: +81-3-5625-8188  
Fax: +81-3-5625-8189

## USA California Office

1801 Highland Ave. Unit A  
Duarte, CA 91010, U.S.A  
Tel: +1-626-844-8888  
Fax: +1-626-844-8838

## USA New York Office

415 Oser Ave Unit S  
Hauppauge, NY 11788  
Sales: +1-631-436-5070  
Fax: +1-631-436-5027

## India Office

Suite 803, 8th Floor,  
Housefin Bhavan,  
C-21 Bandra Kurla Complex,  
Bandra (East), Mumbai 400 051  
Tel: +91 22 6128-8700

## UK Office

Unit 12 Spitfire Business Park Hawker Road  
Croydon, CR0 4WD  
London: 0845 430 9999  
Telford: 0845 430 8888



Your EverFocus product is designed and manufactured with high quality materials and components which can be recycled and reused.  
This symbol means that electrical and electronic equipment, at their end-of-life, should be disposed of separately from your household waste.  
Please, dispose of this equipment at your local community waste collection/recycling centre.  
In the European Union there are separate collection systems for used electrical and electronic product.  
Please, help us to conserve the environment we live in!

Ihr EverFocus Produkt wurde entwickelt und hergestellt mit qualitativ hochwertigen Materialien und Komponenten, die recycelt und wieder verwendet werden können.  
Dieses Symbol bedeutet, dass elektrische und elektronische Geräte am Ende ihrer Nutzungsdauer vom Hausmüll getrennt entsorgt werden sollen.  
Bitte entsorgen Sie dieses Gerät bei Ihrer örtlichen kommunalen Sammelstelle oder im Recycling Centre.  
Helfen Sie uns bitte, die Umwelt zu erhalten, in der wir leben.



**EverFocus**®